

SECTION A-A

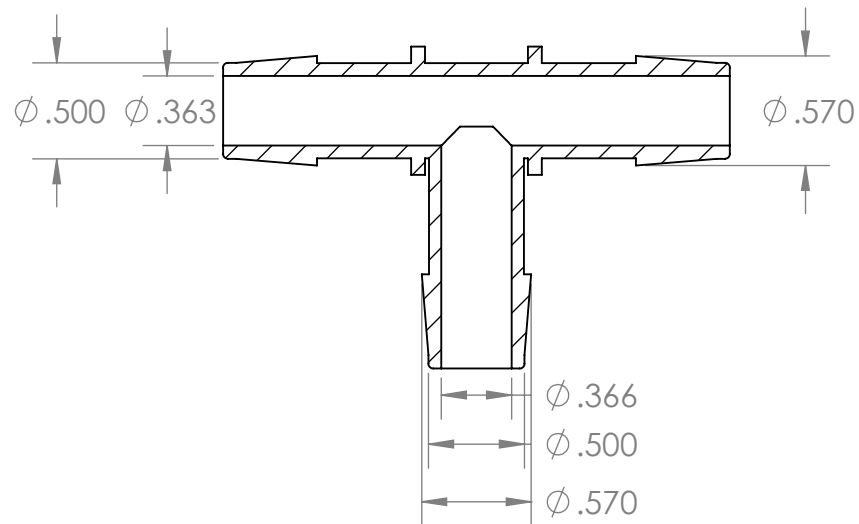
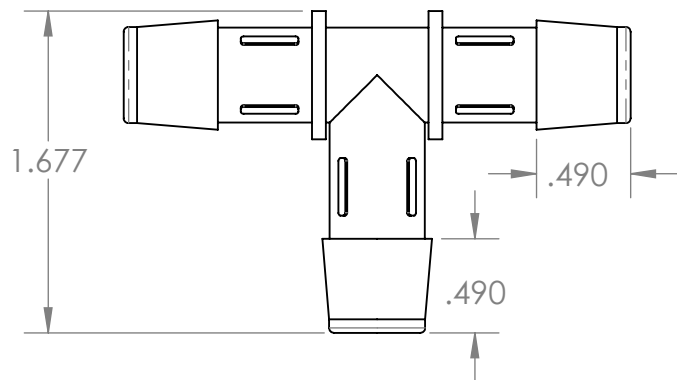

PROPRIETARY AND CONFIDENTIAL

THE INFORMATION CONTAINED IN THIS DRAWING IS THE SOLE PROPERTY OF INDUSTRIAL SPECIALTIES MFG. AND IS MED SPECIALITES. ANY REPRODUCTION IN PART OR AS A WHOLE WITHOUT THE WRITTEN PERMISSION OF INDUSTRIAL SPECIALTIES MFG. AND IS MED SPECIALITES IS PROHIBITED.

UNLESS OTHERWISE SPECIFIED:

DIMENSIONS ARE IN INCHES
 TOLERANCES:
 FRACTIONAL \pm
 ANGULAR: MACH \pm BEND \pm
 TWO PLACE DECIMAL \pm
 THREE PLACE DECIMAL \pm

MATERIAL
 Black Glass Filled Nylon
 FINISH

DO NOT SCALE DRAWING

| | NAME | DATE |
|-----------|------|---------|
| DRAWN | ME | 9/24/13 |
| CHECKED | | |
| ENG APPR. | | |
| MFG APPR. | | |
| Q.A. | | |

Comments:
 Automotive Grade Materials



Industrial Specialties Mfg.
IS Med Specialties

DESCRIPTION:
 1/2" Hose Barb Tee

| | | |
|------------------|-----------------------|--------------|
| SIZE A | PART# TUBJ-12-BGFN | REV 1 |
| SCALE: 1:1 | | SHEET 1 OF 1 |