

TECHNICAL SPECIFICATION

Aseptic Dispense Valve	Part No: 7512-01-9909	Color: Natural
------------------------	-----------------------	----------------

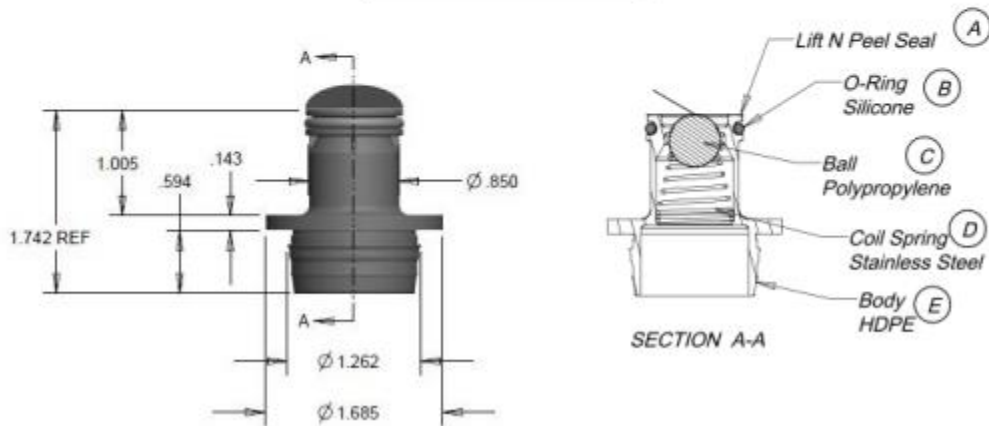

Average Performance Properties for ADV Valve/800 Spout	Typical Value			
Leak Test (psi)	Dust Cap Position		Fully Seated Position	
	11		15	
Press on Force (lbf)	Dust Cap Position		Fully Seated Position	
	48		80	
Removal Force Dust Cap Position (lbf)	14			
Peel Force (lbf)	5.65			
Cocking Force (lbf)	53			
Component Materials (See Below) <i>(All US FDA Compliant for Food Contact.)</i>	Body HDPE	Ball PP	O-Ring Silicone	Spring 302 SS

Lift 'N Peel: FDA 177.1210 (Closures and sealing gaskets); FDA 175.105 (Adhesives); FDA 21CFR177.1520(a)(2)(i),(b) & (c) 3.1; FDA 21CFR170-189(sealant); 177.1630 (Polyethylene Phthalate Polymers) or are GRAS(Generally recognized as safe); Good MFG Practices defined in FDA 21 CFR 174.5 & 21 CFR110
 O-Ring: FDA 21 CFR 1777.2600
 Ball: FDA 21 CFR 1777.1520
 Spring: Passivated
 Body: FDA 21 CFR 177.1520(c)3.2a

Disclaimer: The information given on this spec sheet is supplied in good faith and does not comprise a warranty of any kind either expressed or implied, including those of merchantability and fitness for purpose. It is the customer's responsibility to determine the suitability of this product for their specific application. Tests on individual taps may vary to the data shown. This spec is an uncontrolled copy and is subject to change / improvement without notice.