

SECTION A-A

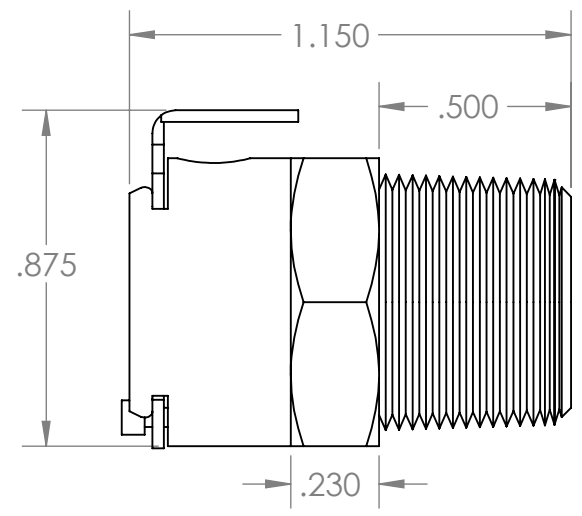

Material List

Material: Brass
 Finish: Chrome
 Pressure Range: Vacuum to 250 psi
 Temp. Range: -40°F to 180°F
 Valve Spring: 316 Stainless Steel
 Seal Options: Buna-N

UNLESS OTHERWISE SPECIFIED:		NAME	DATE
DIMENSIONS ARE IN INCHES TOLERANCES: FRACTIONAL ± ANGULAR: MACH ± BEND ± TWO PLACE DECIMAL ± THREE PLACE DECIMAL ±	DRAWN	ME	6/5/2013
	CHECKED		
	ENG APPR.		
	MFG APPR.		
	Q.A.		
MATERIAL	See Material List		Comments: 1/4" Flow
FINISH	See Material List		
DO NOT SCALE DRAWING			



DESCRIPTION:		
3/8" Male NPT Valved Socket		
SIZE	PART#	REV
A	LCD10006	1
SCALE: 2:1		SHEET 1 OF 1

PROPRIETARY AND CONFIDENTIAL

THE INFORMATION CONTAINED IN THIS DRAWING IS THE SOLE PROPERTY OF INDUSTRIAL SPECIALTIES MFG. AND IS MED SPECIALITES. ANY REPRODUCTION IN PART OR AS A WHOLE WITHOUT THE WRITTEN PERMISSION OF INDUSTRIAL SPECIALTIES MFG. AND IS MED SPECIALITES IS PROHIBITED.