

- NOTES:
 1. ALL DIMENSIONS FOR REFERENCE ONLY
 2. REFER TO AIR LOGIC'S POLYSULFONE APPLICATION GUIDE
 3. TUBE RETENTION PRESSURE SUBJECT TO TUBING DIMENSION AND STIFFNESS

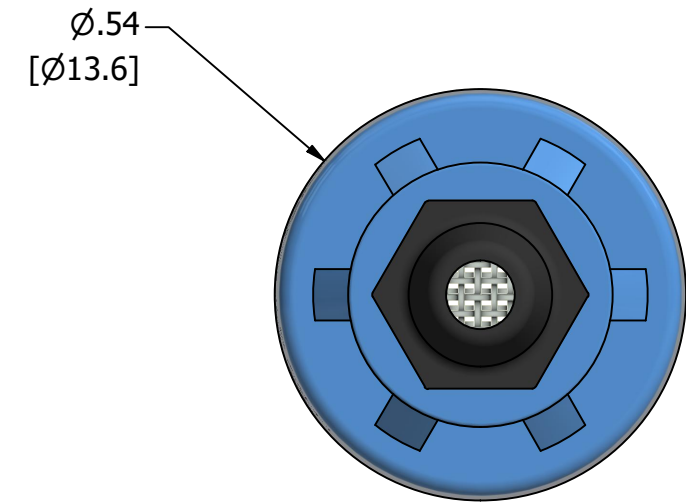
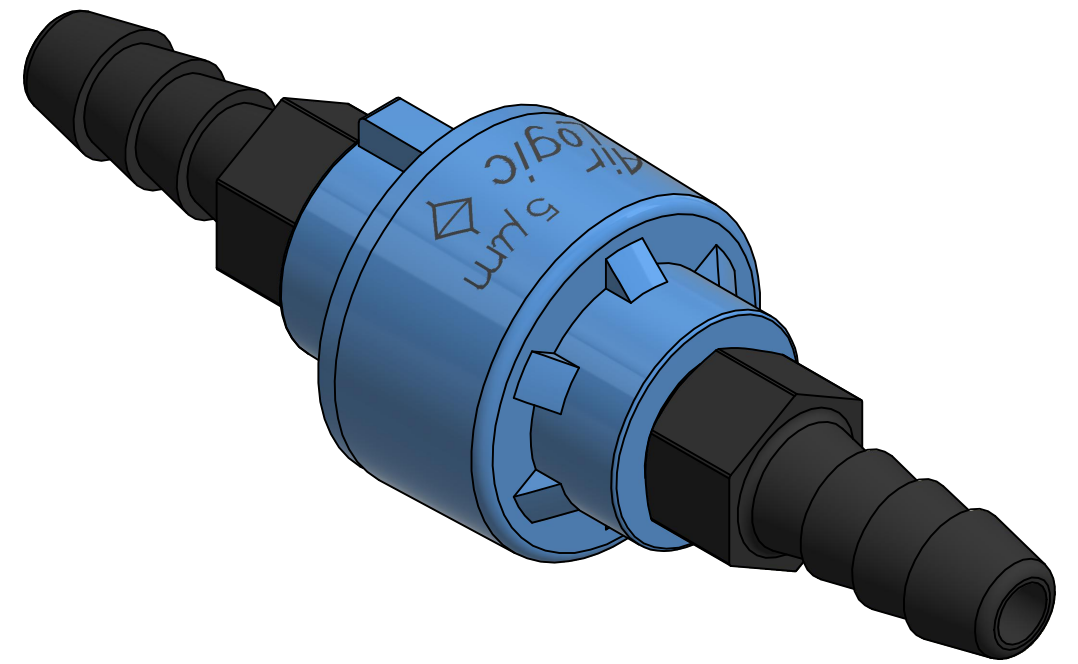
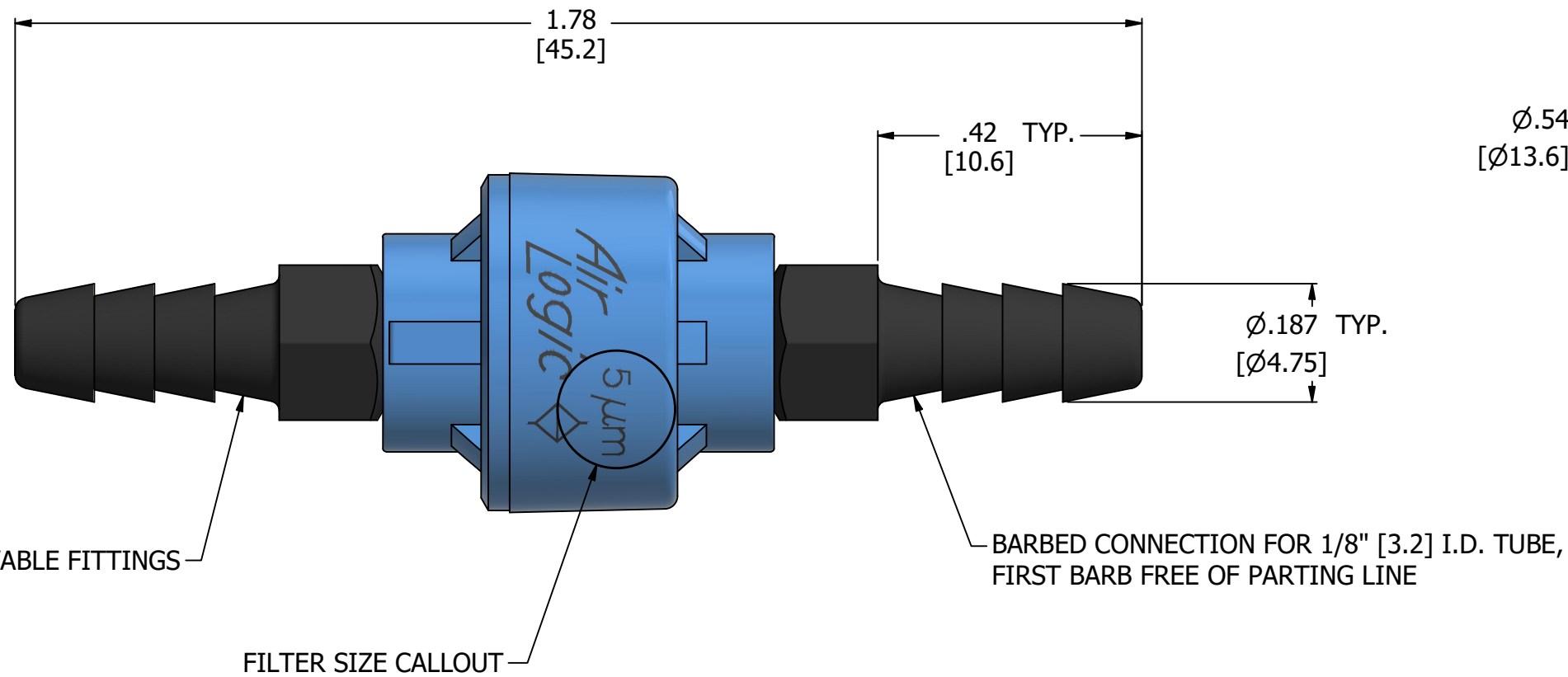

PRODUCT SPECIFICATIONS	
COLOR(S)	LIGHT BLUE, BLACK
FILTER AREA	.164 in ² , [105 mm ²]
FILTER SIZE	5 MICRON
MEDIA	GASES, LIQUIDS, NOTE 2
MAX INLET PRESSURE	125 PSI, [8.6 BAR]
TYPICAL TUBE RETENTION PRESSURE	125 PSI, [8.6 BAR], NOTE 3
MINIMUM INNER DIAMETER DIAMETER	Ø.09 [Ø2.3]
WETTED MATERIALS	POLYSULFONE, STAINLESS STEEL

 AIR-LOGIC © DIVISION OF KNAPP MFG, INC. 5102 DOUGLAS AVE RACINE, WI 53402 PHONE: (262) 639-9035 FAX: (262) 639-5996 WEB: AIR-LOGIC.COM	
PART/DRAWING NO.:	
F9705P85	
DESCRIPTION: INLINE FILTER, 5 MICRON, 1/8" BARBS	
REVISION: A	DRAWN: 2/25/2021
SCALE: 4 : 1	SHEET SIZE: B

TERMS OF USE: THIS DRAWING IS FOR INFORMATIONAL PURPOSES ONLY. AIR LOGIC MAKES NO REPRESENTATIONS OF WARRANTIES CONCERNING SUITABILITY FOR ANY PARTICULAR PURPOSE. ALL PRODUCTS SUPPLIED ARE SUBJECT TO TERMS AND CONDITIONS FOUND AT AIR-LOGIC.COM
DRAWING TAKES PRECEDENCE OVER 3D MODEL GEOMETRY TOLERANCE: DECIMALS .00 ± .01, .000 ± .005, FRACTIONS ± 1/64 ANGLES 1/4° UNLESS OTHERWISE SPECIFIED UNITS: INCHES [MILLIMETERS]