

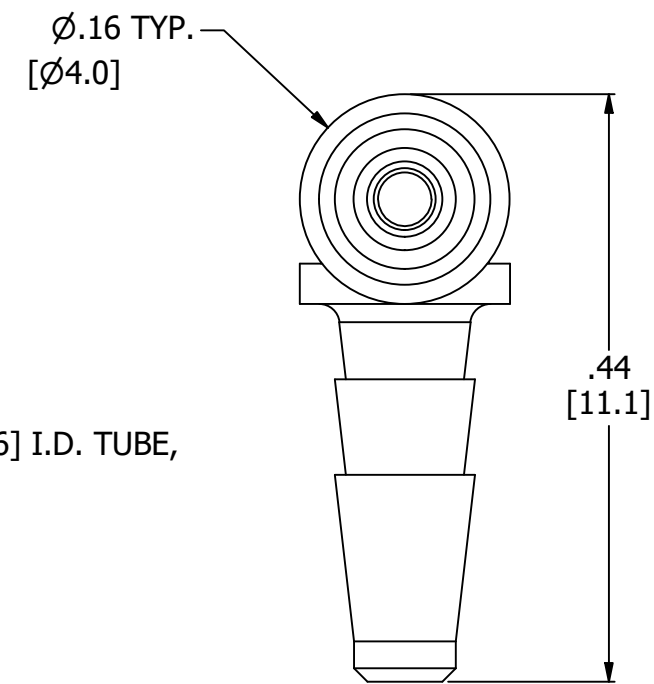

NOTES:

1. ALL DIMENSIONS FOR REFERENCE ONLY
2. TUBE RETENTION PRESSURE SUBJECT TO TUBING DIMENSION AND STIFFNESS

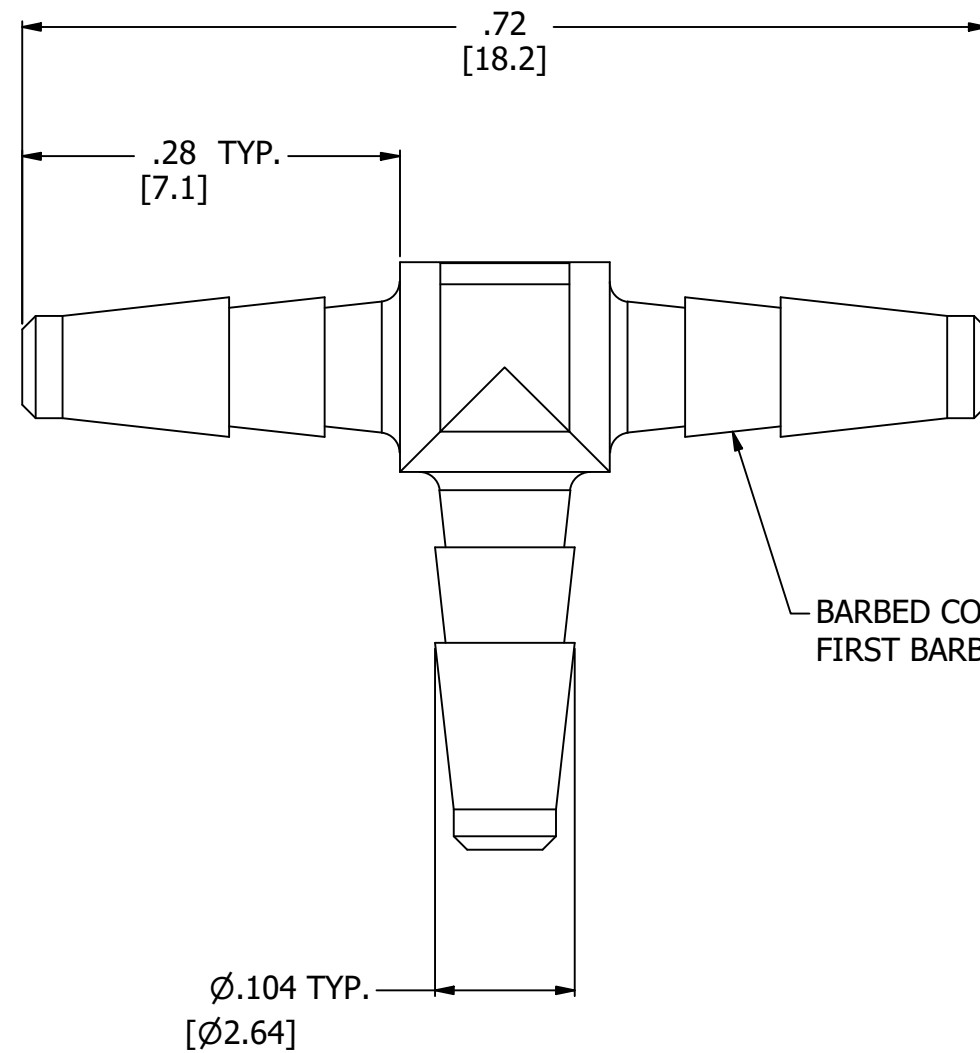
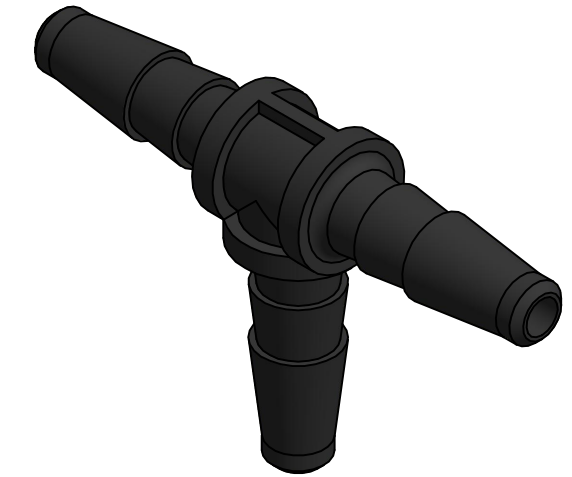

BARBED CONNECTIONS FOR 1/16" [1.6] I.D. TUBE, FIRST BARB FREE OF PARTING LINE

PRODUCT SPECIFICATIONS	
COLOR(S)	BLACK
MEDIA	GASES, LIQUIDS
MAX INLET PRESSURE	125 PSI, [8.6 BAR]
TYPICAL TUBE RETENTION PRESSURE	125 PSI, [8.6 BAR], NOTE 2
MINIMUM INNER DIAMETER	Ø.045, [Ø1.14 BAR]
WETTED MATERIALS	NYLON

 AIR-LOGIC @ DIVISION OF KNAPP MFG, INC. 5102 DOUGLAS AVE RACINE, WI 53402 PHONE: (262) 639-9035 FAX: (262) 639-5996 WEB: AIR-LOGIC.COM	
PART/DRAWING NO.:	
F314580	
DESCRIPTION: NYLON TEE, 1/16" BARBS	
REVISION: A	DRAWN: 2/15/2021
SCALE: 7 : 1	SHEET SIZE: B

TERMS OF USE: THIS DRAWING IS FOR INFORMATIONAL PURPOSES ONLY. AIR LOGIC MAKES NO REPRESENTATIONS OF WARRANTIES CONCERNING SUITABILITY FOR ANY PARTICULAR PURPOSE. ALL PRODUCTS SUPPLIED ARE SUBJECT TO TERMS AND CONDITIONS FOUND AT AIR-LOGIC.COM
DRAWING TAKES PRECEDENCE OVER 3D MODEL GEOMETRY TOLERANCE: DECIMALS .00 ± .01, .000 ± .005, FRACTIONS ± 1/64 ANGLES 1/4° UNLESS OTHERWISE SPECIFIED UNITS: INCHES [MILLIMETERS]