

NOTES:
 1. ALL DIMENSIONS FOR REFERENCE ONLY
 2. TUBE RETENTION PRESSURE SUBJECT TO TUBING DIMENSION AND STIFFNESS

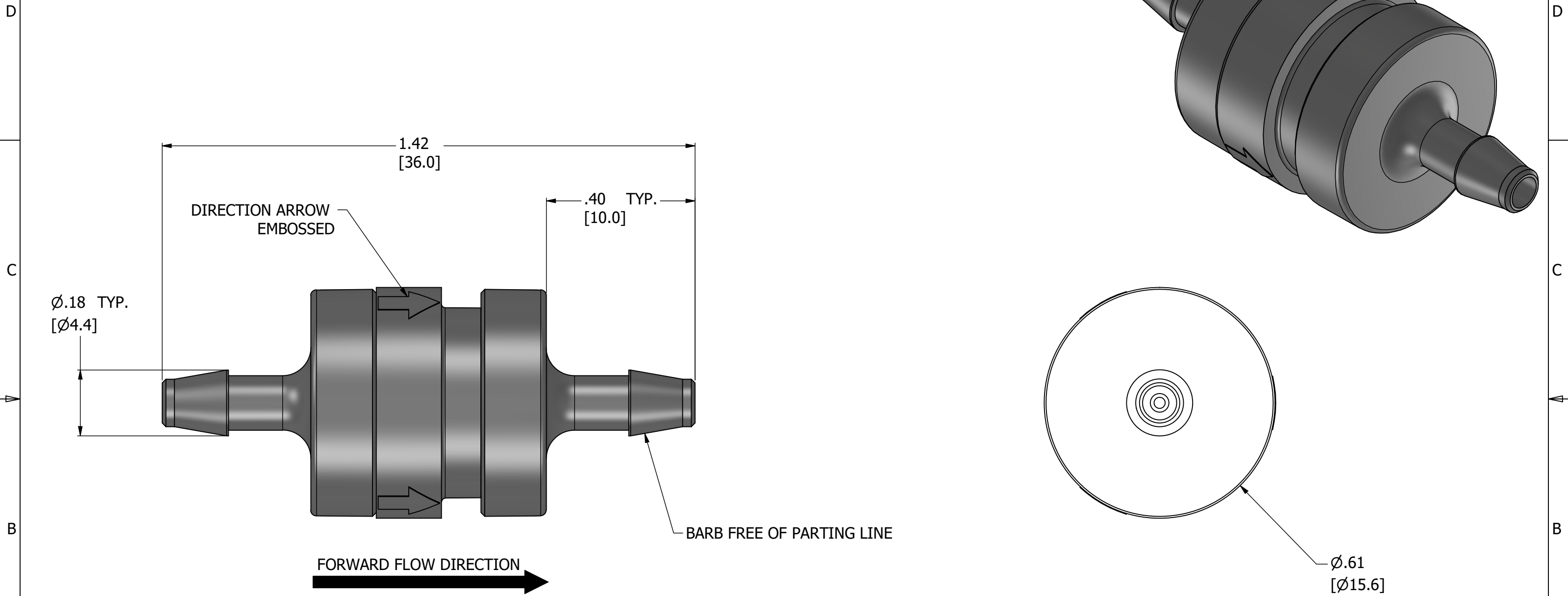

PRODUCT SPECIFICATIONS

| | |
|---------------------------------|---------------------------|
| COLOR(S) | BLACK |
| CHECK VALVE TYPE | UMBRELLA, NORMALLY CLOSED |
| CRACKING PRESSURE | .75±.35 PSI |
| MEDIA | GASES, LIQUIDS |
| MAX PRESSURE | 50 PSI |
| FORWARD FLOW AT 5 PSI | 1.00 SCFM |
| REVERSE FLOW AT 1 PSI | LESS THAN .06 SCIM |
| TYPICAL TUBE RETENTION PRESSURE | 125 PSI, NOTE 2 |
| WETTED MATERIALS | NYLON, VITON |
| RECOMMENDED SYSTEM FILTRATION | 5 MICRON |



AIR-LOGIC @ DIVISION OF KNAPP MFG, INC.
 5102 DOUGLAS AVE RACINE, WI 53402
 PHONE: (262) 639-9035 FAX: (262) 639-5996 WEB: AIR-LOGIC.COM

PART/DRAWING NO.:
F2804410075I5NV

DESCRIPTION:
 .75 PSI CHECK VALVE, 1/8" BARBS, NYLON, VITON

| | |
|--------------|-----------------|
| REVISION: A | DRAWN: 2/7/2024 |
| SCALE: 4 : 1 | SHEET SIZE: B |

TERMS OF USE:
 THIS DRAWING IS FOR INFORMATIONAL PURPOSES ONLY. AIR LOGIC MAKES NO REPRESENTATIONS OF WARRANTIES CONCERNING SUITABILITY FOR ANY PARTICULAR PURPOSE. ALL PRODUCTS SUPPLIED ARE SUBJECT TO TERMS AND CONDITIONS FOUND AT AIR-LOGIC.COM

DRAWING TAKES PRECEDENCE OVER 3D MODEL GEOMETRY
 TOLERANCE: DECIMALS .00 ± .01, .000 ± .005, FRACTIONS ± 1/64
 ANGLES 1/4° UNLESS OTHERWISE SPECIFIED
 UNITS: INCHES [MILLIMETERS]