

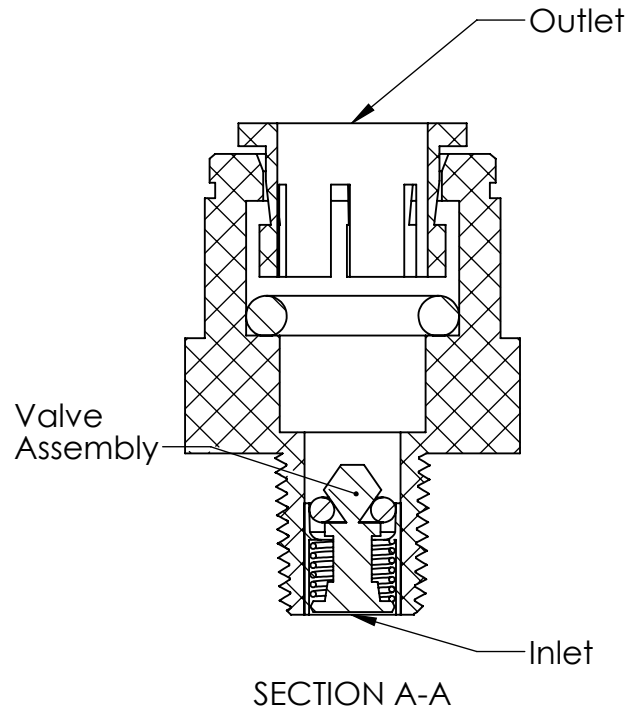

REVISIONS		
REV. 2	Added updated Title Block, Spring Tolerance and Max Operating Pressure	2.2.2026

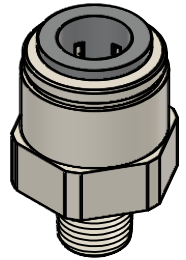
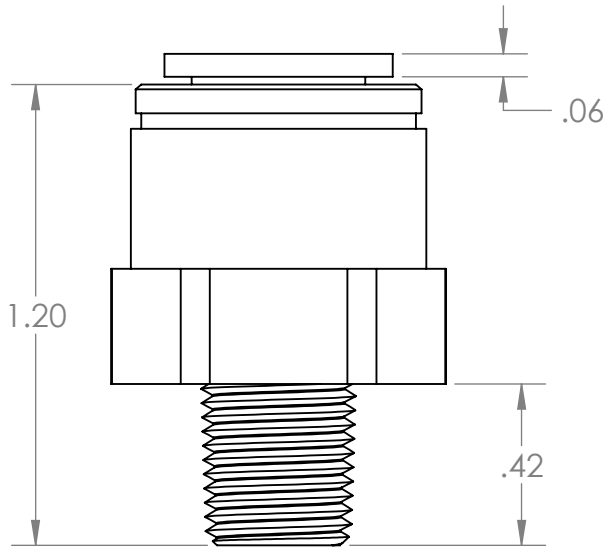
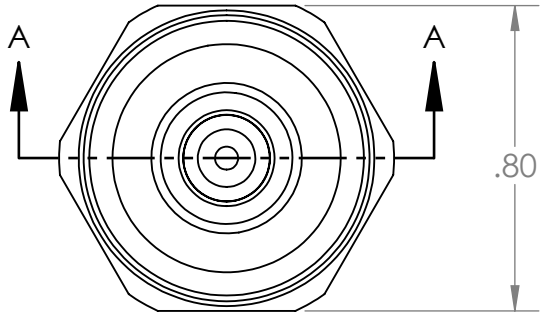

FOR REFERENCE ONLY

NOTE:
25 psi Max Pressure
Spring Tolerance $\pm 30\%$

PROPRIETARY AND CONFIDENTIAL The information contained in this drawing is for reference only and remains the sole property of Industrial Specialties Mfg, Inc and IS Med Specialties (collectively "ISM"). Any reproduction in part or as a whole without the written permission of ISM is prohibited.	Description 1/8" Male NPT x 3/8" Push-In Check Valve, 1 psi Cracking Pressure, Buna-N Seals, Flow from Thread to Push-In, Gray Acetal	NAME	DATE	PART# CVQCS-2M-38-BU-1#	REV 2
		DRAWN BY: M.E.	2.2.2026		
		SHEET 1 OF 1		 Industrial Specialties Mfg. & IS Med Specialties	
		SCALE: 2:1		industrialspec.com 720-729-2202	
DO NOT SCALE DRAWING All Dimensions are in Inches					