

NOTES:

1.  Indicates Control Characteristic.
2. Filter assembly leakage rate must not exceed 0.32 cc/min pressure decay, when subjected to 15 psi.

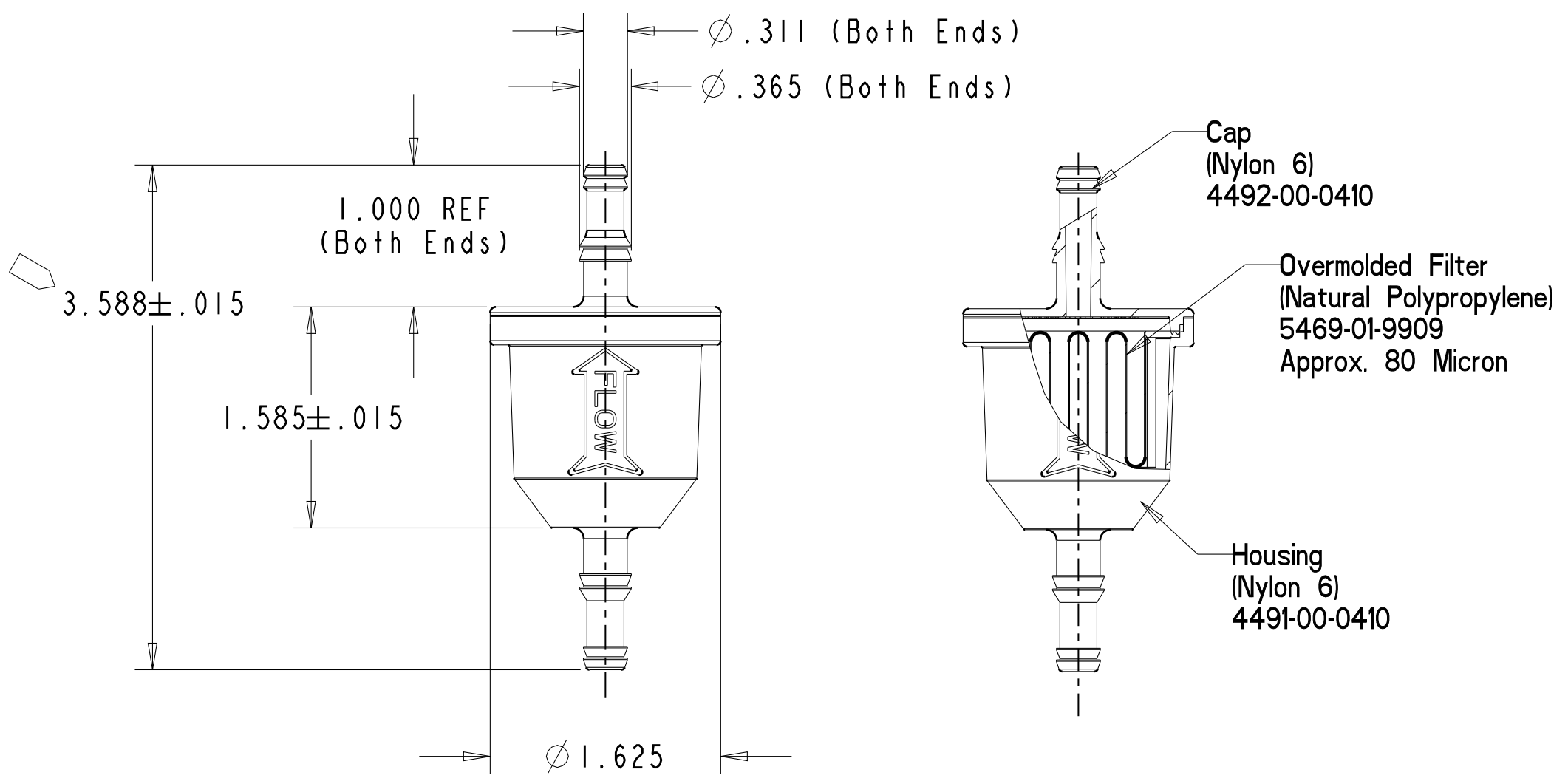

4

5

6

7

8

|     |      |  |          |          |                  |               |  |  |
|-----|------|--|----------|----------|------------------|---------------|--|--|
| 4   | 7222 | Overall length of filter (3.588±.015) changed to controlled dimension.     | BSF      | 06-15-11 | DRAWN BY B. FOOS | DATE 01-14-08 | TOLERANCE UNLESS OTHERWISE INDICATED<br>DECIMAL ± .010<br>ANGULAR ± 2°   | <br>195 ALGONQUIN ROAD / DES PLAINES, IL. 60016 |
| 3   | 7159 | 1.585±.015 -WAS- 1.558±.030  | BSF      | 12-14-10 | CHK BY           | DATE          |  |  |
| 2   | 6981 | TOLERANCE OF 1.558 DIMENSION CHANGED TO +/- .030", 3.558 DIMENSION NOW REF | BSF      | 08-25-09 | APP BY           | DATE          | This print and any design thereon is the property of FASTEX, Division Illinois Tool Works Inc. This print is to be returned upon request or completion of the work for which it was issued. It is to be used only for the purpose for which it was expressly loaned and is not to be copied in any manner, nor is information taken therefrom to be transmitted, or passed on to others without written permission of Illinois Tool Works Inc. |  |
| 1   | 6891 | Released Drawing to Production   | BSF      | 1-20-09  | MATERIAL         |               |  |  |
| NO. | ECN# | REVISION   | APPROVAL | DATE     | HARDNESS         | FINISH        | FTA #  | PROJ# CVA-08-01-002  |
|     |      |  |          |          |                  |               | PART#  | 8479-00-9909   |
|     |      |  |          |          |                  |               | ISSUE  | 4  |

ALL CHANGES TO OCCUR ON CAD SYSTEM

**PRINTED COPIES OF THIS DOCUMENT ARE UNCONTROLLED**