

PROPRIETARY AND CONFIDENTIAL	Description	NAME	DATE	PART#	REV
THE INFORMATION CONTAINED IN THIS DRAWING IS THE SOLE PROPERTY OF INDUSTRIAL SPECIALTIES MFG. AND IS MED SPECIALITES. ANY REPRODUCTION IN PART OR AS A WHOLE WITHOUT THE WRITTEN PERMISSION OF INDUSTRIAL SPECIALTIES MFG. AND IS MED SPECIALITES IS PROHIBITED.	3/8" Inch Hose Barb, Valved Panel Mount Hose Barb Thumb-Latch Type Socket Coupling, 1/4" Flow, Natural Acetal Body, Internal Valve and Terminations, Stainless Steel Thumb-Latch, Springs and Pins, Buna-N O-Ring Seal, Nickel Plated Brass Panel Nut	DRAWN BY: SCW	08-Apr-2015	40ACV-SB3-06	1
		SHEET 1 OF 3		 Industrial Specialties Mfg. IS Med Specialties	
		SCALE 2:1			
		DO NOT SCALE DRAWING			

Specifications

Body and Termination Material	Natural Acetal (POM) - FDA and NSF Compliant for Food Contact
Seal Material Option	Buna-N O-ring - FDA and NSF Compliant for Food Contact O-rings lubricated with Dow Corning 200 food grade silicone oil.
Internal Valve Material	Natural Acetal (POM) - FDA and NSF Compliant for Food Contact
Internal Valve Spring Material	316 Stainless Steel
Thumb-latch Material	301 Stainless Steel
Thumb-latch Spring Material	304 Stainless Steel
Pin Material	316 Stainless Steel
Pin Spring Material	302 Stainless Steel
Panel Mount Nut	13/16" 11/16"-24UNS Electrodeposited Nickel Plated Brass
Operating Pressure Range	Vacuum to 120 psi (8.3 bar)
Operating Temperature Range	-40° F to 180° F (-40° C to 82° C)
Flow Capacity	1/4" Size
Barb Size	3/8", 9.5mm
Compatibility Statement	It is the sole responsibility of the system designer and user to select products suitable for their specific application requirements and to ensure proper installation, operation, and maintenance of these products. Material compatibility, product ratings and application details should be considered in the selection. Improper selection or use of products described herein can cause personal injury or product damage.

Panel Mount Dimensions

	PANEL OPENING	MAX PANEL THICKNESS	MIN PANEL THICKNESS
SOCKETS	See Drawing	0.5"	0.05"
PLUGS	0.688	0.3"	0.05"

PANEL NUT HEX SIZE	PANEL NUT THREAD
13/16"	11/16" - 24UNS

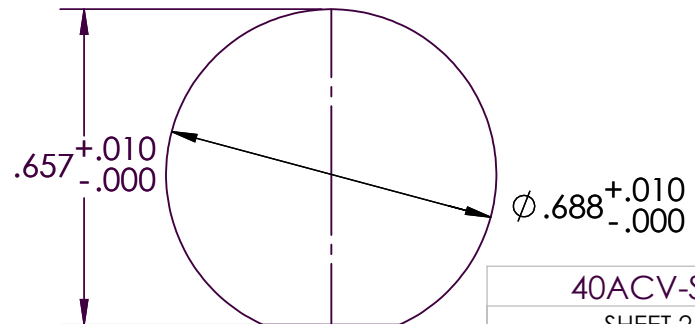

40ACV-SB3-06
SHEET 2 OF 3

40AC Series Air Flow

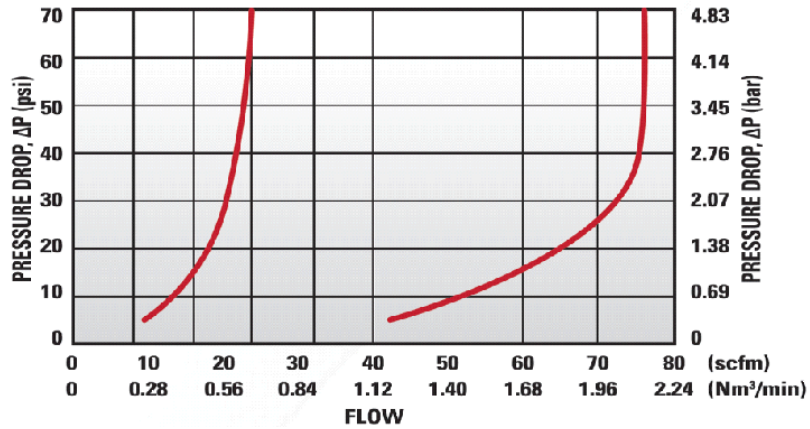

40AC Series Water Flow

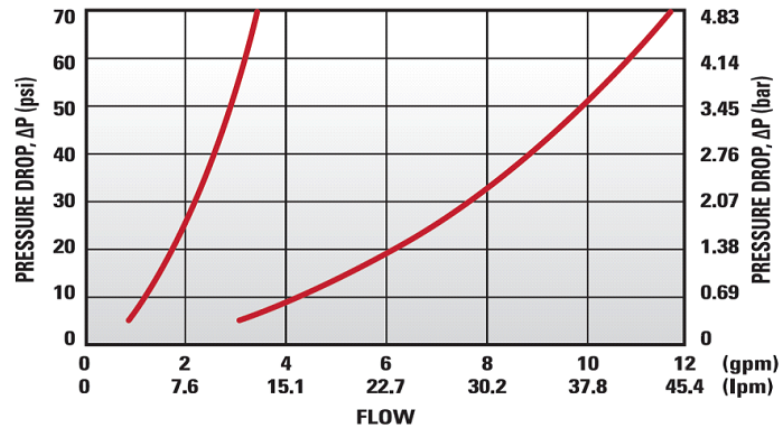

Specific coupling combination flow rates can be determined by using this formula:

$$Q = C_v \times \text{SQRT}(\Delta P / S)$$

SQRT = Square root
 Q = Flow rate in gallons per minute
 C_v = Average flow rate (see chart)
 ΔP = Pressure drop across coupling (psi)
 S = Specific gravity of liquid

C_v Values for the 40ACV-SB3-06

Valved Panel Mount Hose Barb Socket Coupling

Plugs:	40ACV-PB2-04	40AC-PB2-04	40ACV-PB2-06	40AC-PB2-06	40ACV-PB9-04	40AC-PB9-04
40ACV-SB3-06	0.43	0.63	0.50	0.89	0.33	0.39

Plugs:	40ACV-PB9-06	40AC-PB9-06	40ACV-PB1-04	40AC-PB1-04	40ACV-PB1-06	40AC-PB1-06
40ACV-SB3-06	0.62	0.50	0.45	0.95	0.50	0.92