

LEFT VIEW

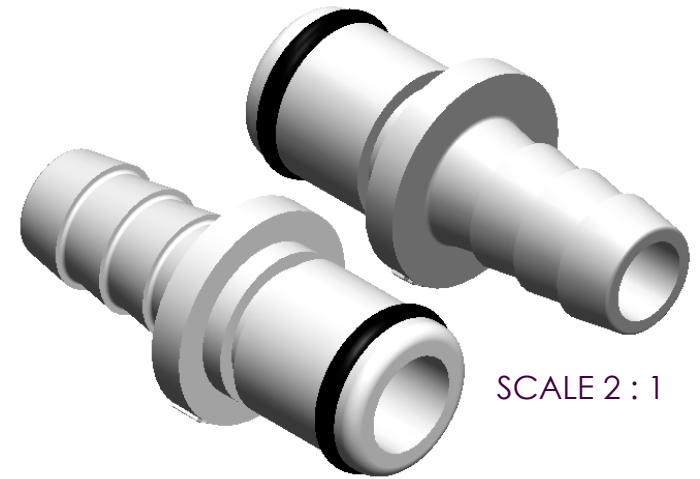

SCALE 2 : 1

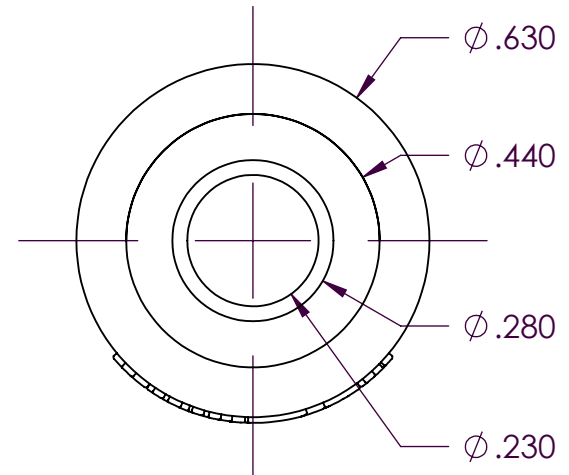
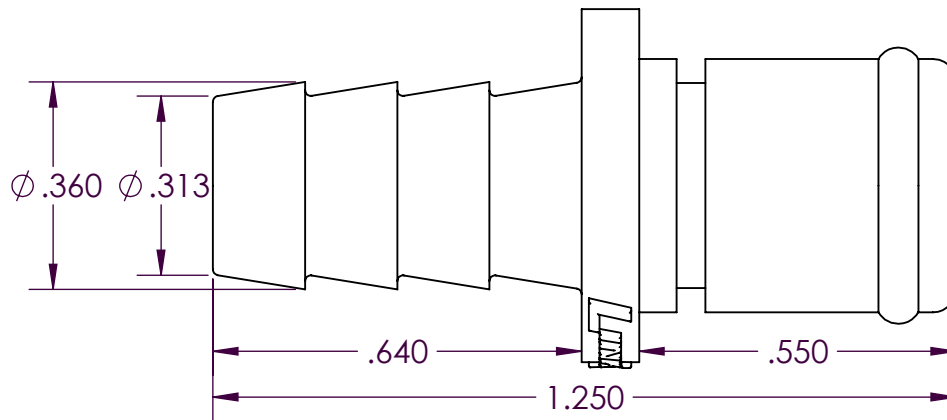

PROPRIETARY AND CONFIDENTIAL

Description

THE INFORMATION CONTAINED IN THIS DRAWING IS THE SOLE PROPERTY OF INDUSTRIAL SPECIALTIES MFG. AND IS MED SPECIALITES. ANY REPRODUCTION IN PART OR AS A WHOLE WITHOUT THE WRITTEN PERMISSION OF INDUSTRIAL SPECIALTIES MFG. AND IS MED SPECIALITES IS PROHIBITED.

5/16" Hose Barb,
Non-Valved In-Line Hose Barb Plug Coupling,
1/4" Flow,
Natural Acetal Body and Terminations
Buna-N O-Ring Seal

NAME	DATE
DRAWN BY: SCW	11-MAR-2016

PART#

40AC-PB2-05

REV
1

SHEET 1 OF 3

SCALE 3 : 1

DO NOT SCALE DRAWING



Industrial Specialties Mfg.
IS Med Specialties

Specifications

Body and Termination Material	Natural Acetal (POM) - FDA and NSF Compliant for Food Contact
Seal Material Option	Buna-N O-ring - FDA and NSF Compliant for Food Contact O-rings lubricated with Dow Corning 200 food grade silicone oil.
Operating Pressure Range	Vacuum to 120 psi (8.3 bar)
Operating Temperature Range	-40° F to 180° F (-40° C to 82° C)
Flow Capacity	1/4" Size
Barb Size	5/16" ID Tube Size (7.9mm ID)
Compatibility Statement	<p>It is the sole responsibility of the system designer and user to select products suitable for their specific application requirements and to ensure proper installation, operation, and maintenance of these products.</p> <p>Material compatibility, product ratings and application details should be considered in the selection. Improper selection or use of products described herein can cause personal injury or product damage.</p>

40AC Series Air Flow

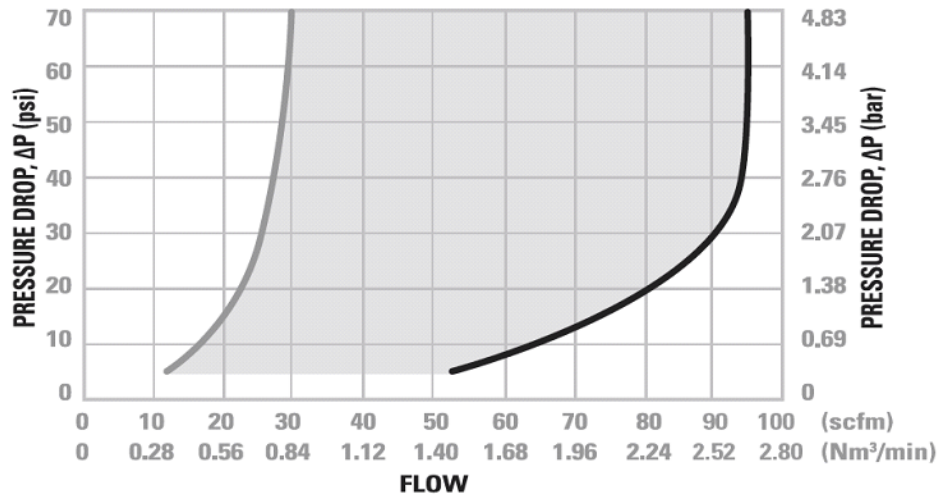

40AC Series Water Flow

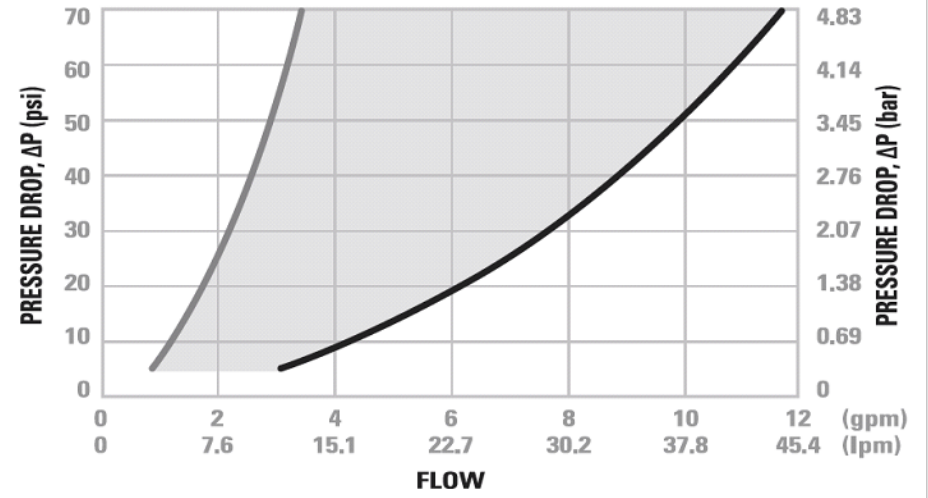

Valved Socket & Plug



Valved & Non-Valved Coupling Set



Non-Valved Socket & Plug



These graphs are intended to give you a general idea of the performance capabilities of the product line.