

SCALE 1.5 : 1

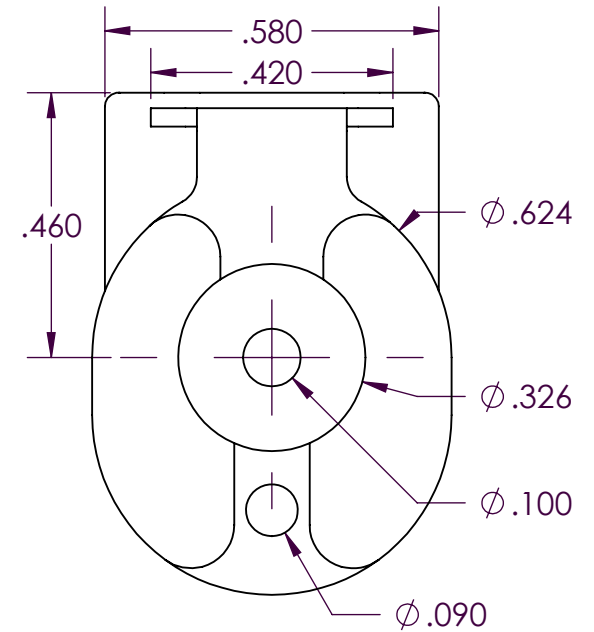
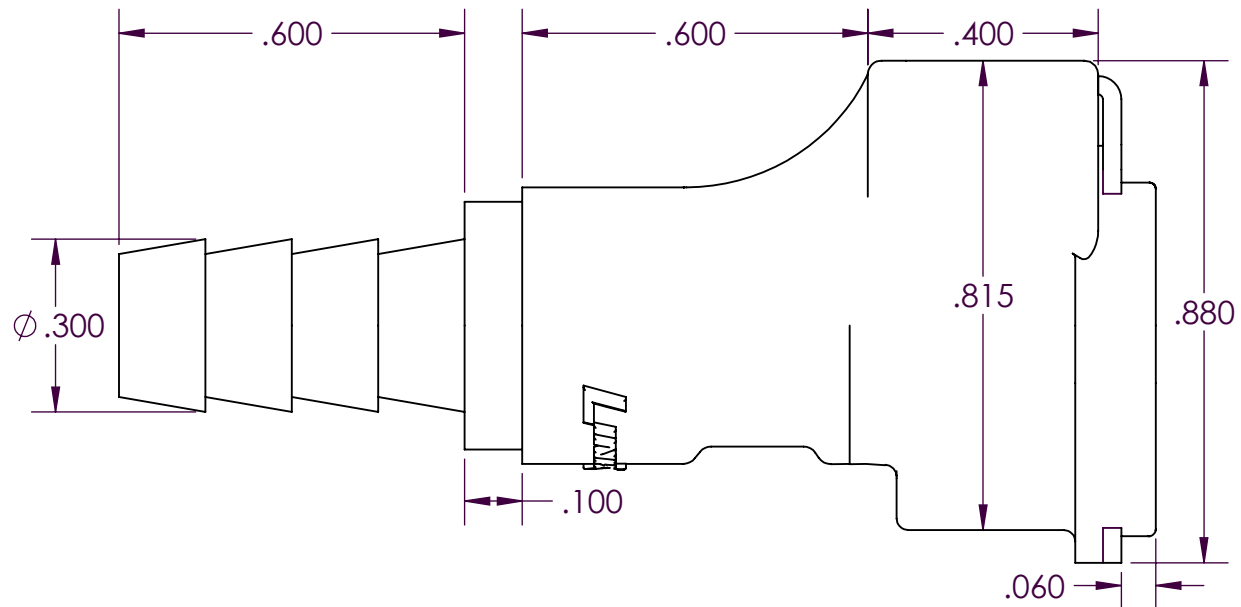

PROPRIETARY AND CONFIDENTIAL

Description

THE INFORMATION CONTAINED IN THIS DRAWING IS THE SOLE PROPERTY OF INDUSTRIAL SPECIALTIES MFG. AND IS MED SPECIALITES. ANY REPRODUCTION IN PART OR AS A WHOLE WITHOUT THE WRITTEN PERMISSION OF INDUSTRIAL SPECIALTIES MFG. AND IS MED SPECIALITES IS PROHIBITED.

1/4" Hose Barb, Non-Valved In-Line Hose Barb Socket Thumb-Latch Type Coupling, 1/8" Flow, Gray Polypropylene Body and Terminations, Stainless Steel Thumb-Latch, External Springs and Pins

NAME DATE
DRAWN BY: SCW 08-Dec-14

PART# REV
20PP-S2-04 1

SHEET 1 OF 3

SCALE 3:1

DO NOT SCALE DRAWING



Industrial Specialties Mfg.
IS Med Specialties

Specifications

Body and Termination Material	Medical Grade Polypropylene
Standard Color Option	Gray
Thumb-latch Material	301 Stainless Steel
Thumb-latch Spring Material	304 Stainless Steel
Pin Material	316 Stainless Steel
Pin Spring Material	302 Stainless Steel
Operating Pressure Range	Vacuum to 120 psi (8.3 bar)
Operating Temperature Range	32° F to 160° F (0° C to 71° C)
Flow Capacity	1/8" Size
Hose Barb Size	1/4" ID, 6.4mm ID
Sterilization	Gamma; 50 kGy irradiation max
Compatibility Statement	<p>It is the sole responsibility of the system designer and user to select products suitable for their specific application requirements and to ensure proper installation, operation, and maintenance of these products.</p> <p>Material compatibility, product ratings and application details should be considered in the selection. Improper selection or use of products described herein can cause personal injury or product damage.</p>

20PP Series Temperature

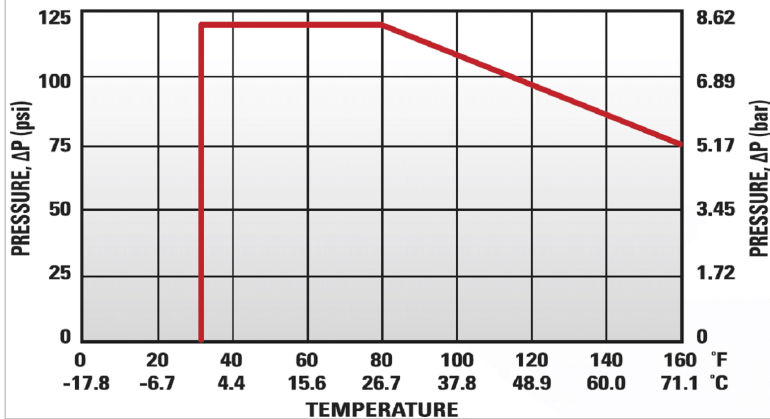

20PP Series Medical Grade Polypropylene Sterilization and Disinfectant Compatibility

Formalin	Isopropyl Alcohol	Ethyl Alcohol	Ethylene Oxide (EtO)
Excellent	Excellent	Excellent	Excellent

Autoclave	E-Beam (50 kGy)	Gamma 5 Mrad (50kGy)	Dry Heat (250° F)
Do Not Use	Excellent	Excellent	Do Not Use

20PP Series Air Flow

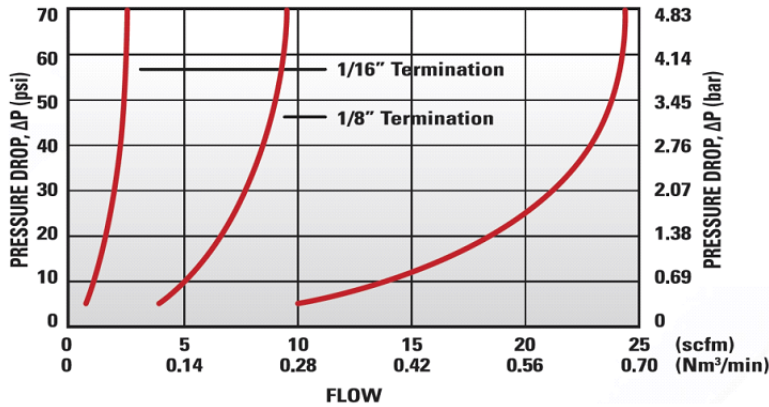

20PP Series Water Flow

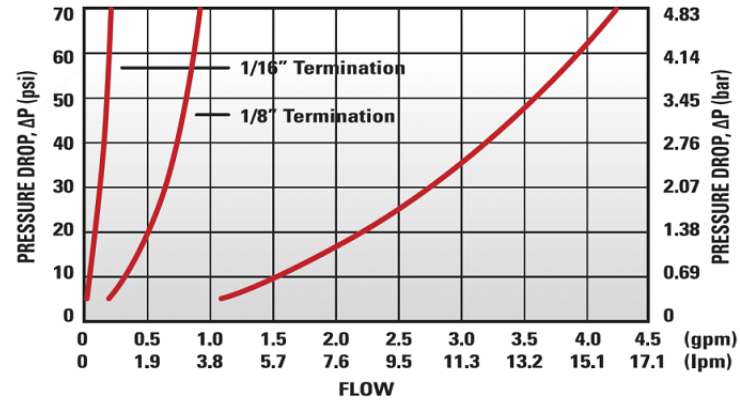

These graphs are intended to give you a general idea of the performance capabilities of the product line.

<p>Specific coupling combination flow rates can be determined by using this formula:</p>	$Q = C_v \times \text{SQRT}(\Delta P / S)$ <p>SQRT = Square root Q = Flow rate in gallons per minute C_v = Average flow rate (see chart) ΔP = Pressure drop across coupling (psi) S = Specific gravity of liquid</p>
--	--

C_v Values for the 20PP-S2-04 Non-Valved In-Line Hose Barb Socket Coupling

Plugs:	20PPV- PE2-01	20PP- PE2-01	20PPV- PE2-02	20PP- PE2-02	20PPV- PE2-04	20PP- PE2-04
20PP-S2-04	0.03	0.03	0.18	0.24	0.23	0.45

Plugs:	20PPV- PE9-04	20PPX- PE9-04	20PPV- PE1-02	20PPX- PE1-02	20PPV- PE4-04	20PPX- PE4-04
20PP-S2-04	0.24	0.33	0.20	0.45	0.27	0.45