

SCALE 1.5 : 1

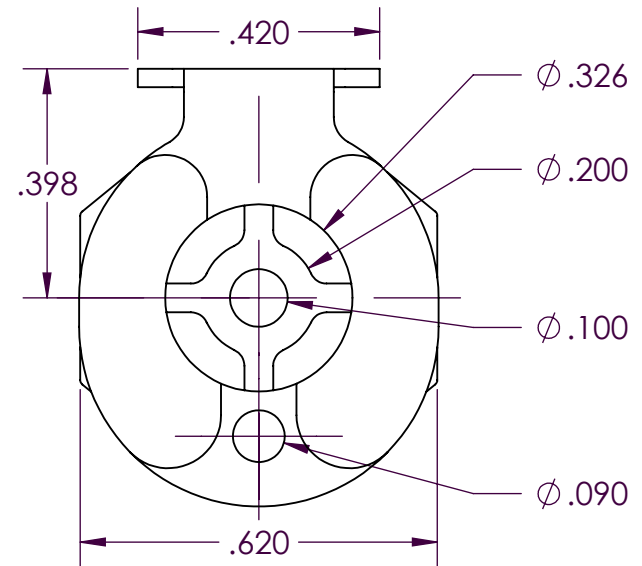
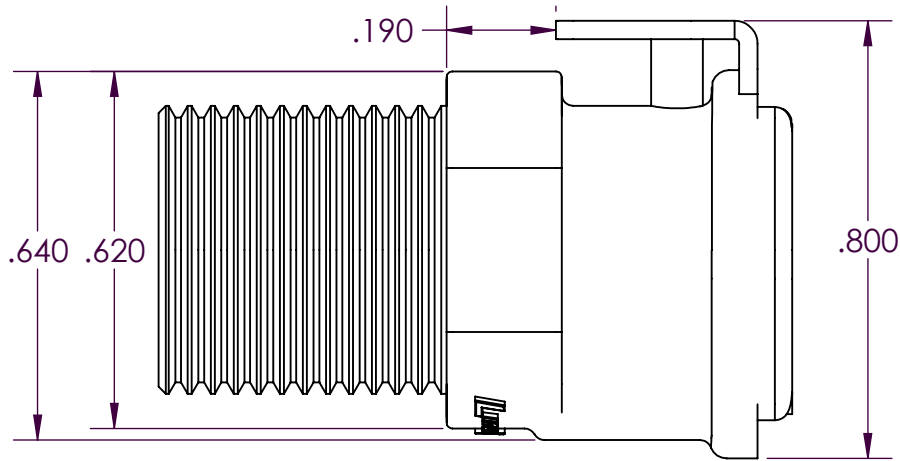

PROPRIETARY AND CONFIDENTIAL

Description

THE INFORMATION CONTAINED IN THIS DRAWING IS THE SOLE PROPERTY OF INDUSTRIAL SPECIALTIES MFG. AND IS MED SPECIALITES. ANY REPRODUCTION IN PART OR AS A WHOLE WITHOUT THE WRITTEN PERMISSION OF INDUSTRIAL SPECIALTIES MFG. AND IS MED SPECIALITES IS PROHIBITED.

1/4" Male NPT Valved Socket Thumb-Latch Type Coupling, 1/8" Flow, Buna-N O-ring Seal, Natural Acetal Body and Terminations, Stainless Steel Thumb-Latch, External Springs and Pins

NAME	DATE
SCW	20-Oct-14

PART#

20ACV-SB1-04

REV  
1

SHEET 1 OF 3

SCALE 3:1

DO NOT SCALE DRAWING



**Industrial Specialties Mfg.**  
**IS Med Specialties**

# Specifications

Body and Termination Material	Natural Acetal (POM) - FDA and NSF Compliant for Food Contact
Seal Material Option	Buna-N O-ring - FDA and NSF Compliant for Food Contact
Internal Valve Material	Natural Acetal (POM) - FDA and NSF Compliant for Food Contact
Internal Valve Spring Material	316 Stainless Steel
Thumb-latch Material	301 Stainless Steel
Thumb-latch Spring Material	304 Stainless Steel
Pin Material	316 Stainless Steel
Pin Spring Material	302 Stainless Steel
Thread Size	1/4" NPT
Operating Pressure Range	Vacuum to 120 psi (8.3 bar)
Operating Temperature Range	-40° F to 180° F (-40° C to 82° C)
Flow Capacity	1/8" Size
Compatibility Statement	<p>It is the sole responsibility of the system designer and user to select products suitable for their specific application requirements and to ensure proper installation, operation, and maintenance of these products.</p> <p>Material compatibility, product ratings and application details should be considered in the selection. Improper selection or use of products described herein can cause personal injury or product damage.</p>

## 20AC Series Air Flow

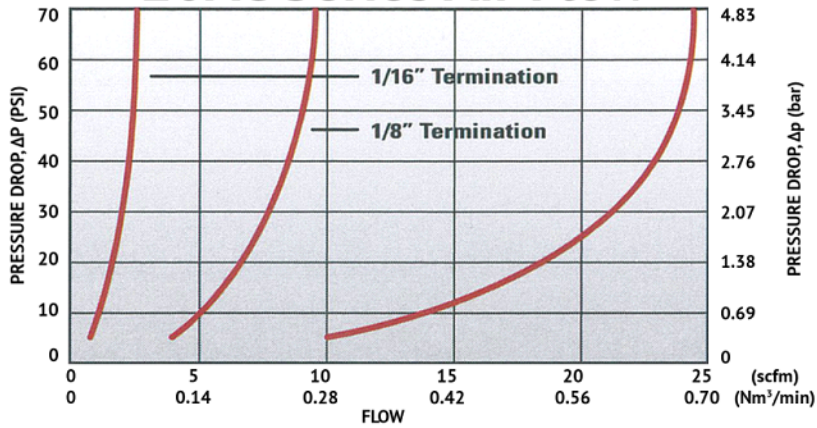

## 20AC Series Water Flow

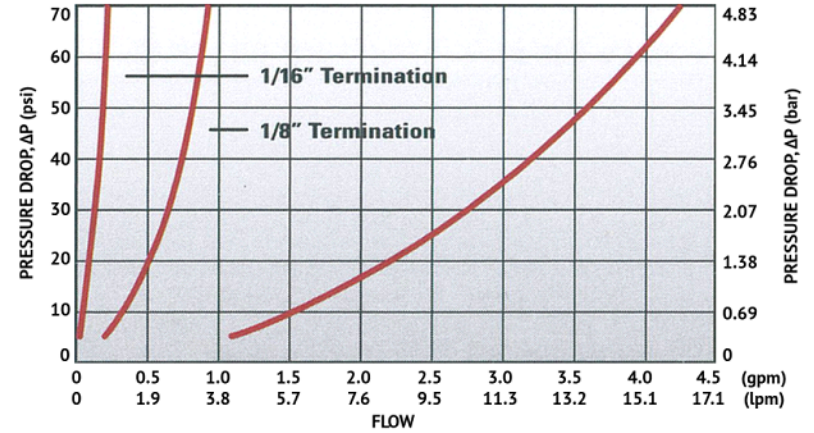

Specific coupling combination flow rates can be determined by using this formula:

$$Q = C_v \times \text{SQRT}(\Delta P / S)$$

SQRT = Square root

Q = Flow rate in gallons per minute

$C_v$  = Average flow rate (see chart)

$\Delta P$  = Pressure drop across coupling (psi)

S = Specific gravity of liquid

### $C_v$ Values for the 20ACV-SB1-04 Valved Socket Coupling

Plugs:	20ACV-PB2-01	20AC-PB2-01	20ACV-PB2-02	20AC-PB2-02	20ACV-PB2-03	20AC-PB2-03	20ACV-PB2-04	20AC-PB2-04
20ACV-SB1-04	0.03	0.03	0.17	0.25	0.18	0.25	0.23	0.30

Plugs:	20ACV-PB9-04	20AC-PB9-04	20ACV-PB1-02	20AC-PB1-02	20ACV-PB1-04	20AC-PB1-04	20ACV-PB4-04	20AC-PB4-04
20ACV-SB1-04	0.19	0.30	0.21	0.27	0.23	0.28	0.24	0.29