

SCALE 2 : 1

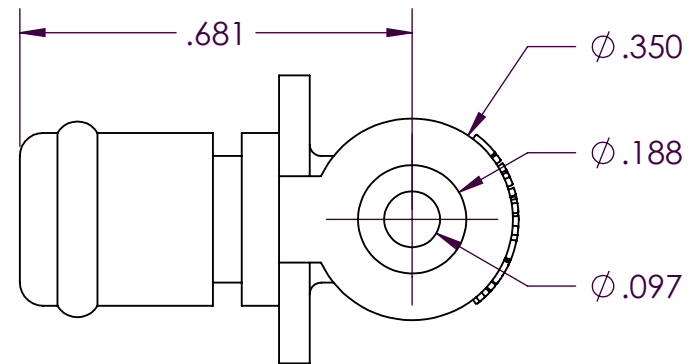
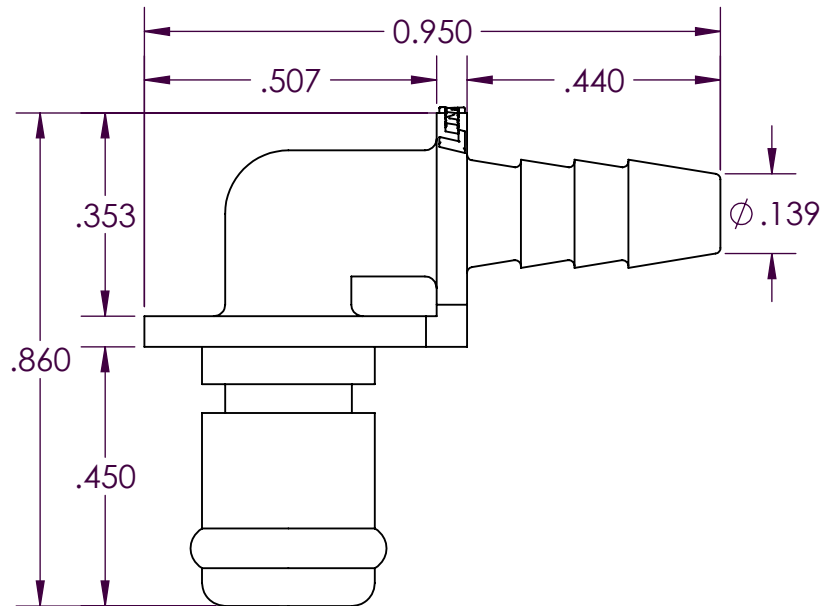

PROPRIETARY AND CONFIDENTIAL

Description

THE INFORMATION CONTAINED IN THIS DRAWING IS THE SOLE PROPERTY OF INDUSTRIAL SPECIALTIES MFG. AND IS MED SPECIALITES. ANY REPRODUCTION IN PART OR AS A WHOLE WITHOUT THE WRITTEN PERMISSION OF INDUSTRIAL SPECIALTIES MFG. AND IS MED SPECIALITES IS PROHIBITED.

1/8" Hose Barb,  
Non-Valved Elbow Hose Barb Plug Coupling,  
1/8" Flow,  
Natural Acetal Body and Terminations,  
Buna-N O-ring Seal

NAME	DATE
SCW	11-Nov-14

PART#	REV
20AC-PB4-02	1

SHEET 1 OF 3

SCALE 3:1

DO NOT SCALE DRAWING



**Industrial Specialties Mfg.**  
**IS Med Specialties**

# Specifications

Body and Termination Material	Natural Acetal (POM) - FDA and NSF Compliant for Food Contact
Seal Material Option	Buna-N O-ring - FDA and NSF Compliant for Food Contact O-rings lubricated with Dow Corning 200 food grade silicone oil.
Operating Pressure Range	Vacuum to 120 psi (8.3 bar)
Operating Temperature Range	-40° F to 180° F (-40° C to 82° C)
Flow Capacity	1/8" Size
Barb Size	1/8" ID Tube Size
Compatibility Statement	<p>It is the sole responsibility of the system designer and user to select products suitable for their specific application requirements and to ensure proper installation, operation, and maintenance of these products.</p> <p>Material compatibility, product ratings and application details should be considered in the selection. Improper selection or use of products described herein can cause personal injury or product damage.</p>

# 20AC Series Air Flow

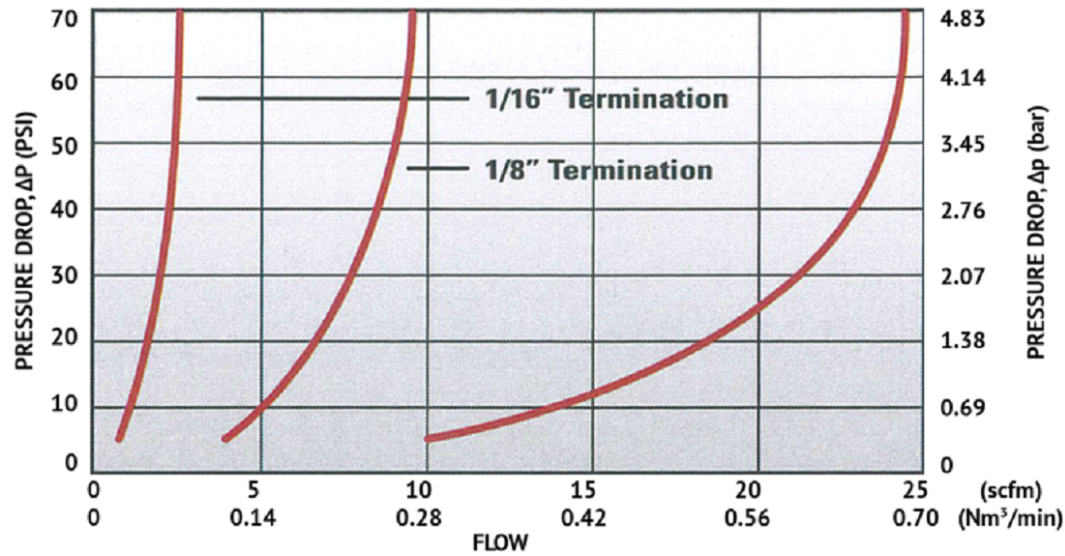

# 20AC Series Water Flow

