

SECTION A-A

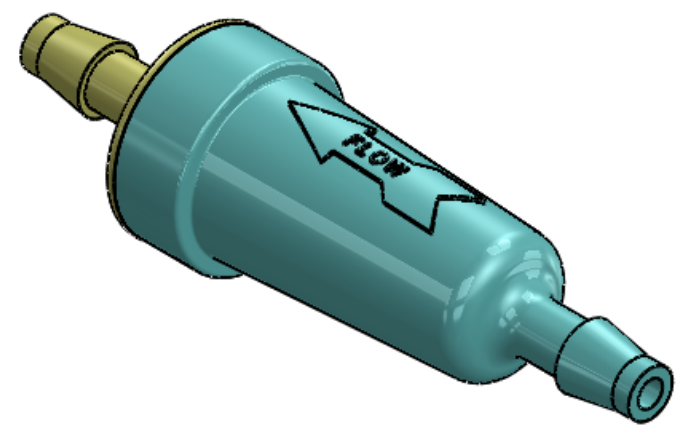
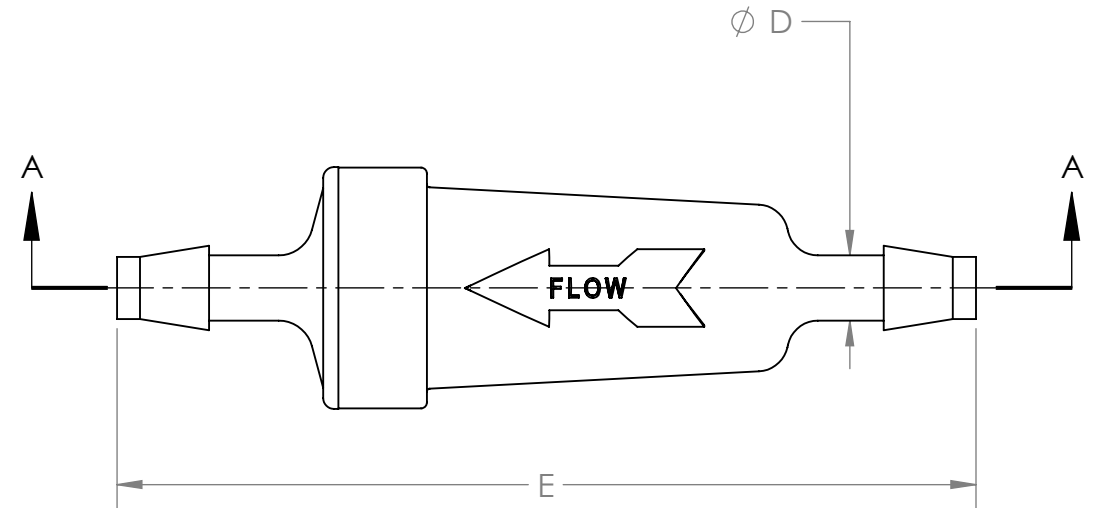

NOTE:.....

REVISIONS				
DATE	ECN	REV.	DESCRIPTION	APPROVED
10-18-11	-	1	RELEASE FOR TOOLING	WLC/CB
11-15-12	-	2	GENERAL UPDATE	JXG
2-27-13	-	3	UPDATED ASSY LENGTH / GENERAL UPDATE	JXG
4-24-13	-	4	REDRAWN ON 'B' SIZE / ADDED DIMS TO CHART	JXG
7-27-13	-	5	ADDED 0085160-00-380	BGM

PART NUMBER	PORE SIZE	ELEMENT COLOR	SCREEN MATERIAL	ELEMENT RESIN	HOUSING MATERIAL	HOUSING COLOR	1	2	3	4	5
							DIA. A +/- 0.010	DIA. B +/- 0.005	DIA. C +/- 0.005	DIA. D +/- 0.005	E +/- 0.020
0085160-00-110	10 u	YELLOW	NYLON 6/6	NYLON 6	ACETAL	NATURAL	0.630	0.220	0.090	0.170	2.230
0085160-00-120	10 u	YELLOW	NYLON 6/6	NYLON 6	NYLON 6	NATURAL	0.635	0.220	0.090	0.170	2.240
0085160-00-140	48 u	BLUE	NYLON 6/6	NYLON 6	NYLON 6	NATURAL	0.635	0.220	0.090	0.170	2.240
0085160-00-150	65 u	WHITE	POLYESTER	NYLON 6	NYLON 6	NATURAL	0.635	0.220	0.090	0.170	2.240
0085160-00-180	250 u	GREEN	NYLON 6	NYLON 6	NYLON 6	NATURAL	0.635	0.220	0.090	0.170	2.240
0085160-00-380	250 u	GREEN	NYLON 6	NYLON 6	NYLON6	BLACK	0.635	0.220	0.090	0.170	2.240
-	-	-	-	-	-	-	-	-	-	-	-

PROPRIETARY AND CONFIDENTIAL
 THE INFORMATION CONTAINED IN THIS DRAWING IS THE SOLE PROPERTY OF ITW FASTEX FILTRATION. ANY REPRODUCTION IN PART OR AS A WHOLE WITHOUT THE WRITTEN PERMISSION OF ITW FASTEX FILTRATION IS PROHIBITED.

UNLESS OTHERWISE SPECIFIED:	
DIMENSIONS ARE IN INCHES	
TOLERANCES:	
FRACTIONAL ±	
ANGULAR: MACH ± BEND ±	
TWO PLACE DECIMAL ±	
THREE PLACE DECIMAL ±	
INTERPRET GEOMETRIC TOLERANCING PER:	
MATERIAL	
FINISH	
APPLICATION	DO NOT SCALE DRAWING

NAME	DATE
WLC	10-18-11
DRAWN	
CHECKED	
ENG APPR.	
MFG APPR.	
Q.A.	
COMMENTS:	

ITW FASTEX FILTRATION

TITLE:
**SMALL IN-LINE ASSEMBLY
 1/8" PORTS**

SIZE	DWG. NO.	REV
B	0085160-00-XXX	5

SCALE: 2:1 WEIGHT: SHEET 1 OF 1